

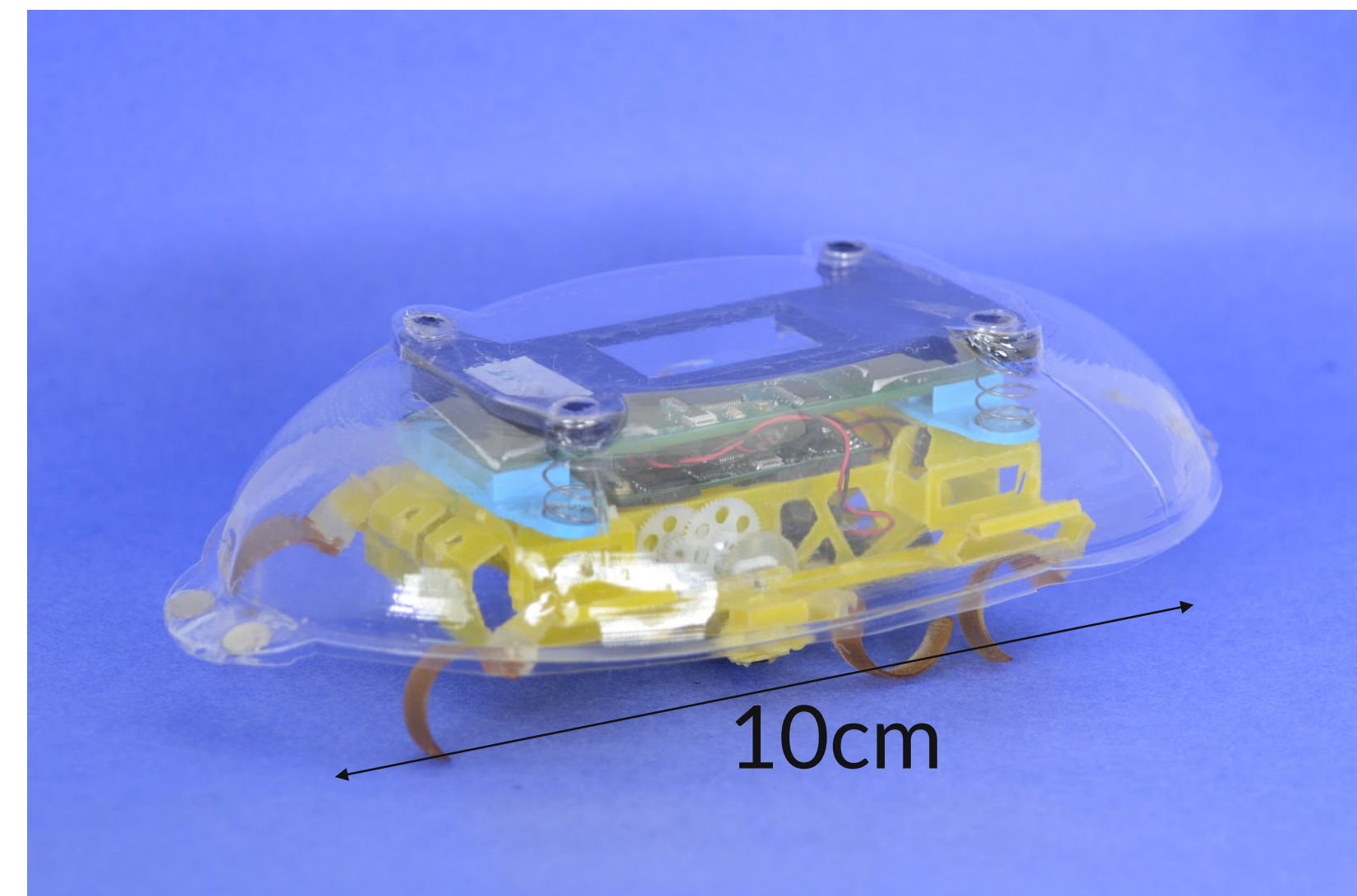

Terrain Classification with Force-Torque Sensor Equipped Millirobot



Tactile robot in natural environment.



Robot model with tactile shell.



High resistance region

Objective

Goal:
Distinguish low and high resistance regions.

Why?

- Low vision environments, e.g. Dirt,
- Navigating through brush or dense compliant obstacles

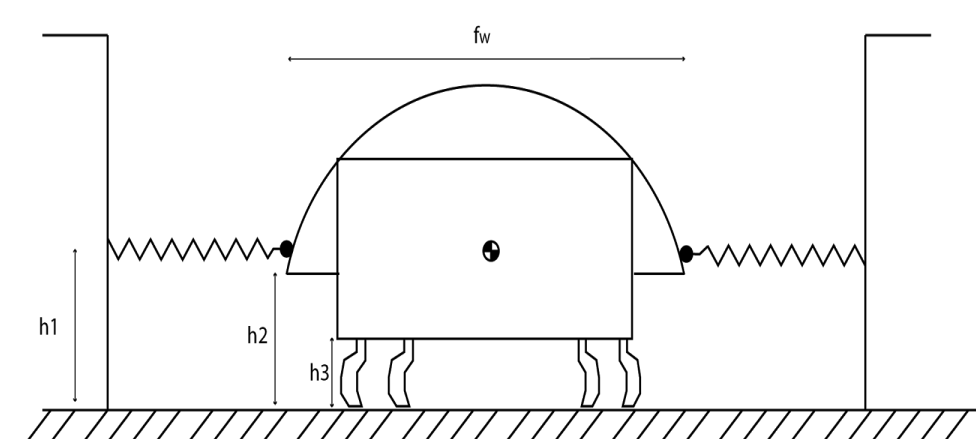
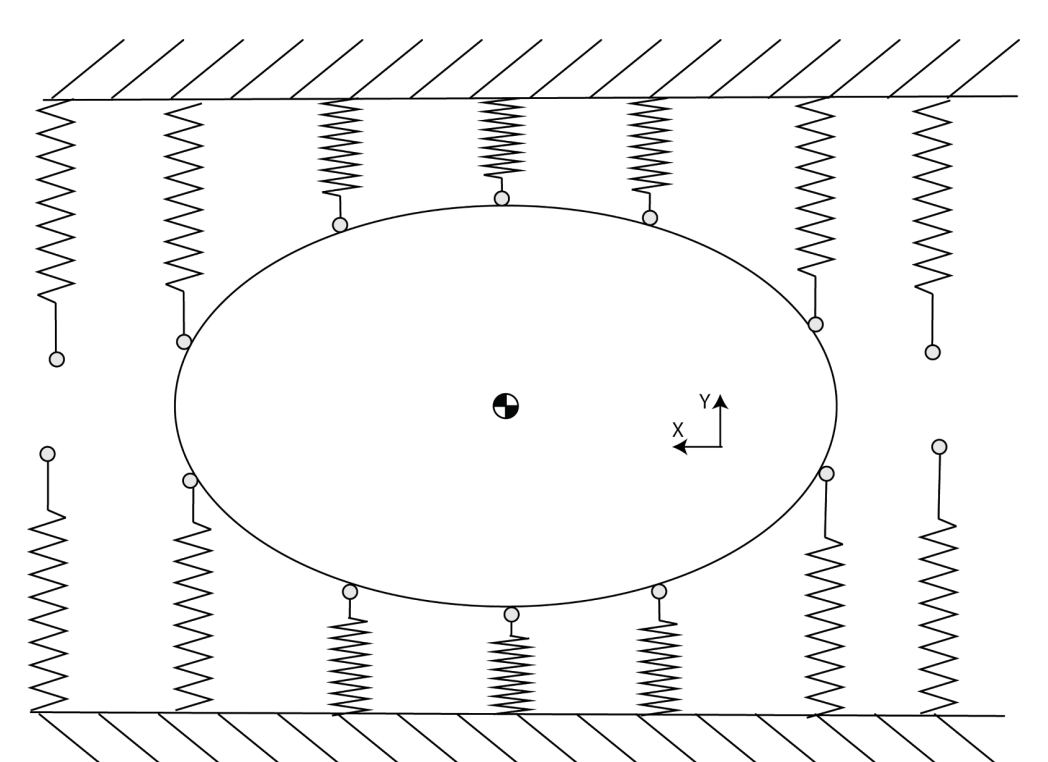
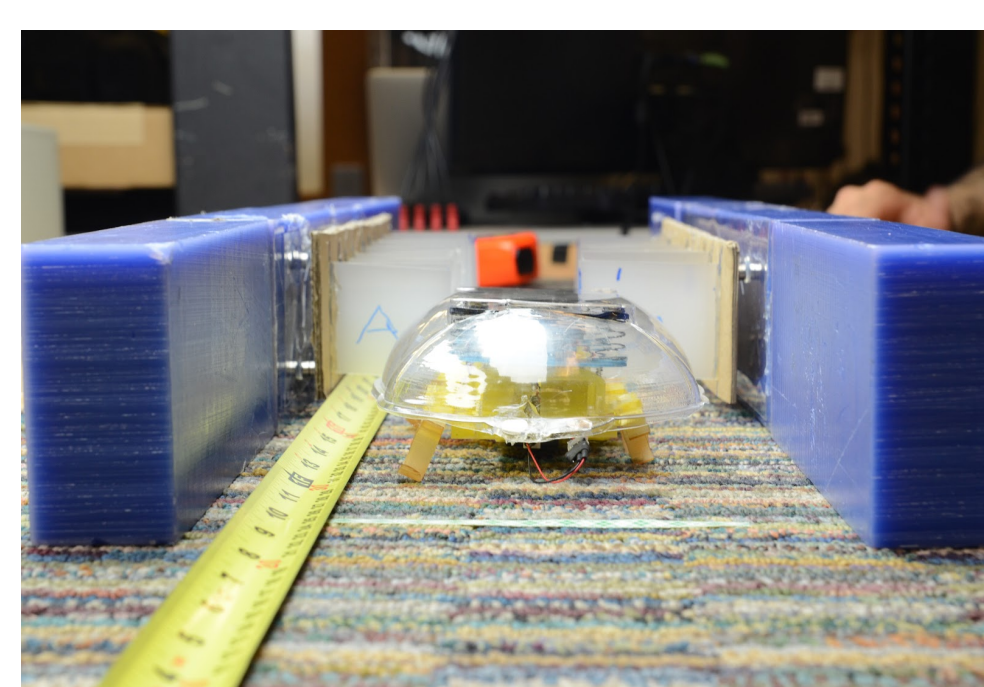
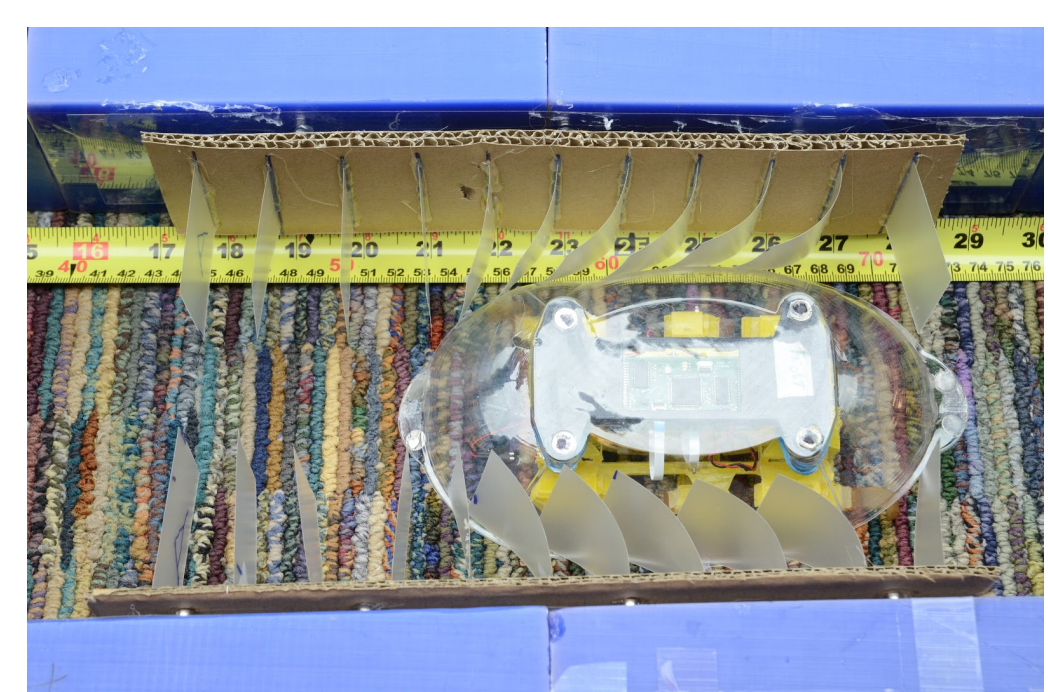

Method

- Our experiment setup has 3 states: start (no touch), traversal (touch) and exit (no touch).
- Dataset consists of all the experiments from 4,6,8 and 10cm flap widths.
- After segmenting and applying windows we labeled the data as touch (1) or no touch (0).

Training Set:

772 samples (1) + 853 samples (0).

Test Set:

Single experiment with 4cm.

Results

- Input: shell forces, F_x , F_y , F_z , Gyro, Accelerometer, Leg Positions and Velocity.
- Trained random forests, gradient boosted trees, RBF SVM, and Neural Network
- All had a 10-fold CV average ROC score $>.9$

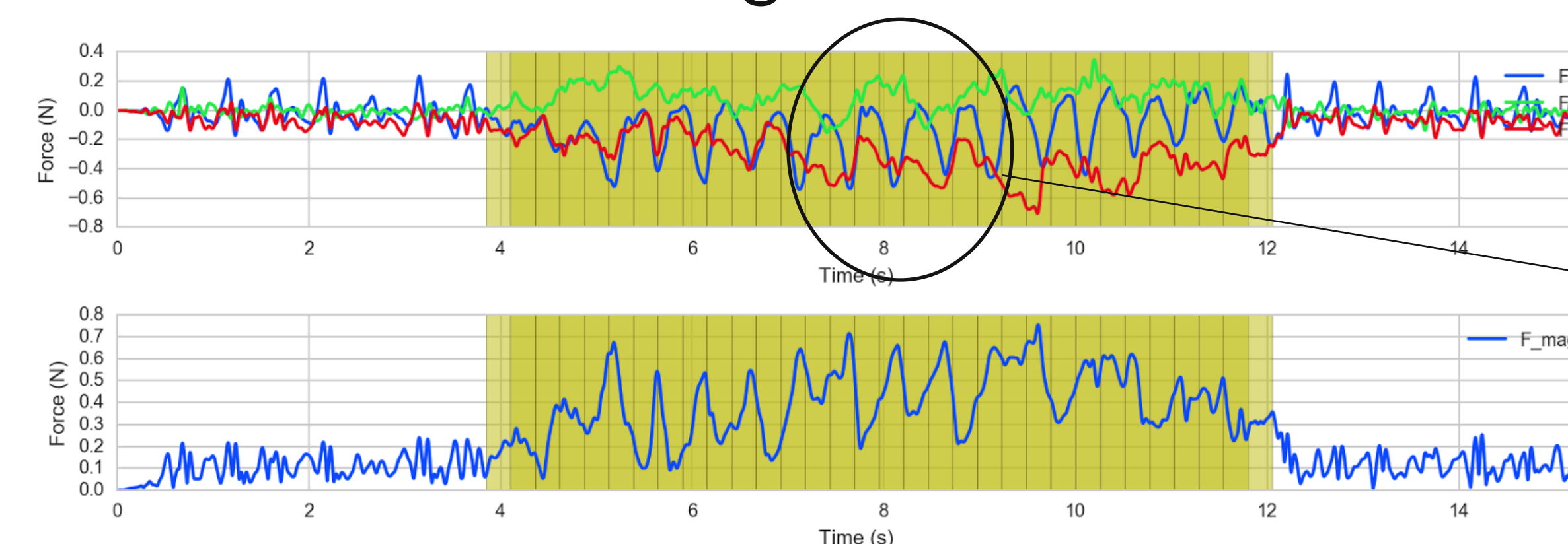

Detail of single cycle

Classifier	10-fold CV avg ROC	Gradient Trees Top Features	Random Forests Top Features
Random Forests	97.4%	F_z_max	F_x_skew
Gradient Boosted Trees	97.6%	F_x_skew	F_mag_energy
RBF SVM	97.3%	F_mag_max	F_mag_mean
Neural Network	92%	F_z_mean	Mx_std
		My_min	F_mag_max